

SERVICE INSTRUCTIONS

TURBINE MIXERS

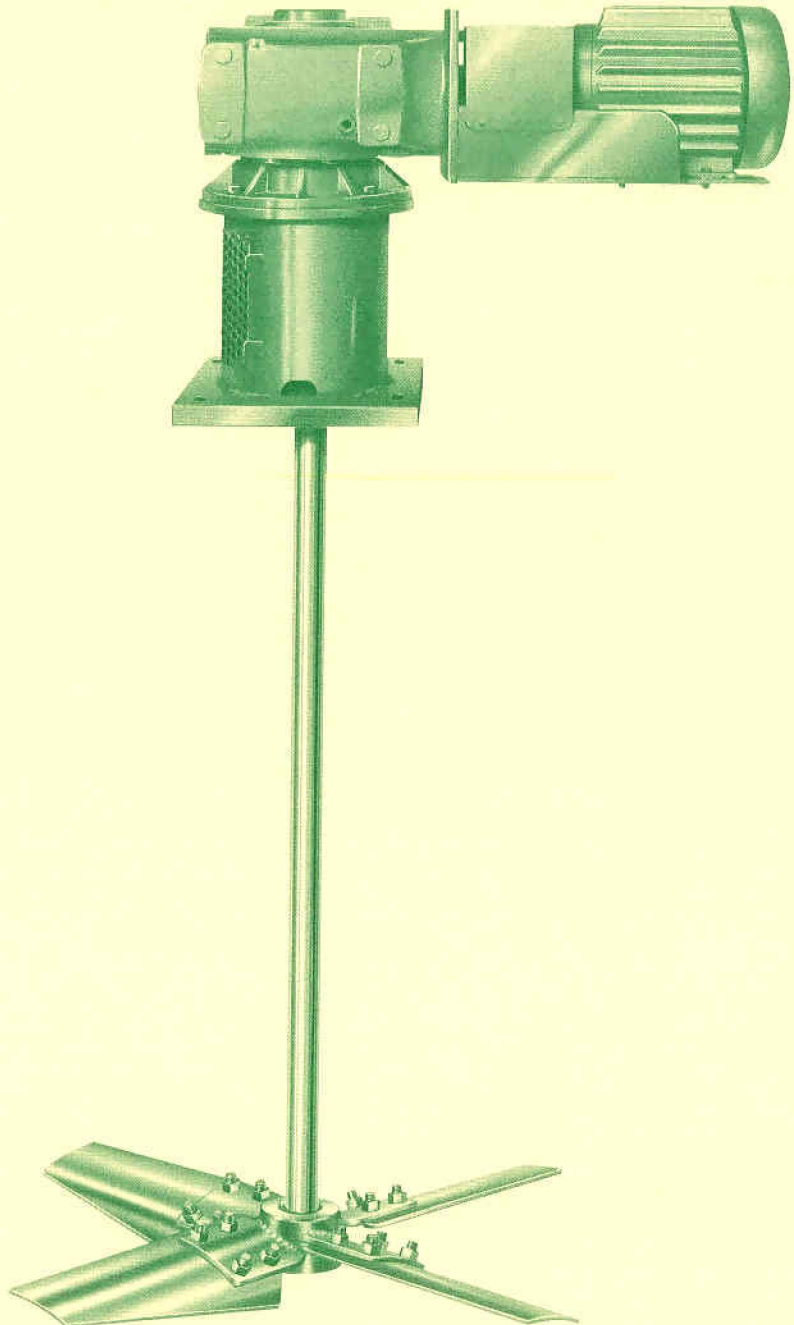

3131 Casitas Avenue
Los Angeles, California 90039
Phone: (323) 664-1941 • FAX: (323) 660-5677
www.mixmor.com

MIXMOR



SERVICE INSTRUCTIONS

TURBINE MIXER MODEL TO, TCL & TC
DRIVE SERIES 'F'
MANUAL NO. 05-47775

CUSTOMER:

P.O. NO.:

ITEM NO.:

MIXER MODEL NO.:

MIXER SERIAL NO.:

DRIVE SERIES & SIZE:

MIXER SHAFT SPEED:

SHAFT COUPLING DESIGN:

DATE:

MIXMOR
3131 CASITAS AVENUE
LOS ANGELES, CA 90039
TELE: 323.664.1941
FAX: 323.660.5677
E-MAIL: info@mixmor.com

TABLE OF CONTENTS

	<u>PAGE</u>
FOREWORD.....	1
GENERAL INFORMATION.....	1
HANDLING INSTRUCTIONS.....	2
SAFETY	
HANDLING	
INSTALLATION INSTRUCTIONS.....	3-7
STORAGE	
LOCATION	
MOUNTING	
GEAR REDUCER	
FLEXIBLE COUPLING	
MIXER SHAFT	
IMPELLER	
FLANGE COUPLING DWG. NO. 05-08505	
HOLLOW SHAFT ASSEMBLY DWG. NO. 05-47924	
IMPELLER DRAWING NO. 05-03915 & 05-09023	
MODEL "TO", BASEPLATE BEARING AND PARTS.....	8-9
GENERAL INFORMATION	
BASEPLATE BEARING LUBRICATION	
MODEL "TO" PARTS DRAWING NO. 05-01605	
MODEL "TCL" & "TC".....	10-12
GENERAL INFORMATION	
LUBRICATION	
START-UP INSTRUCTIONS	
REPACKING PROCEDURE	
MODEL "TCL" DRAWING NO. 05-01604	
MODEL "TC" DRAWING NO. 05-01606	
STEADY BEARING.....	13
INSTALLATION	
DRAWING NO. 05-09794	
GEAR REDUCER LUBRICATION.....	14-16
FILL LEVEL & DRAIN PLUGS	
LUBRICANTS	
LUBRICANT CAPACITY	
AUTOVENT PLUG	
MAINTENANCE	
OIL SPECIFICATIONS	
AUTOMATIC LUBRICATOR	
START-UP INSTRUCTIONS.....	17
GEAR REDUCER.....	18-27
PREVENTATIVE MAINTENANCE	
TROUBLE SHOOTING	
FLEXIBLE COUPLINGS	
OIL LEAKAGE PROTECTION CHAMBER	
DRIVE SERIES F22 thru F52 PARTS DWG. NO. 05-47925	
DRIVE SERIES F62 thru F82 PARTS DWG. NO. 05-48004	
OUTPUT ASSEMBLY PARTS DWG. NO. 05-48005	
INPUT ASSEMBLY PARTS DWG. NO. 05-47823	
INPUT ASSEMBLY PARTS DWG. NO. 05-47824	
INPUT ASSEMBLY PARTS DWG. NO. 05-47755	
MAINTENANCE RECORD.....	28
MIXER CERTIFIED DRAWING	

FOREWORD

The information contained in this service instruction manual covers MixMor Model TO, TCL and TC Mixers with 'F' Series drive.

The mounting and/or mixer shaft seal determines the model. The following is a description of the models.

"TO" – Baseplate mounted for channel mounting over open tanks.

"TCL" – Flange mounted mixers with low-pressure stuffing box (10 PSIG maximum) for closed tank application.

"TC" – Flange mounted mixers with high-pressure stuffing box (150 PSIG maximum) for closed tank application.

The front page of this manual and the certified drawing gives the model and drive type and size of your mixer.

We have included information in this manual that covers installation, start-up, service, and trouble shooting to assure years of reliable mixer service. Should questions or problems occur that are not covered in this manual, consult your local representative or phone MixMor at our Los Angeles, California plant (323) 664-1941.

GENERAL INFORMATION

When apparent or suspected damage has been found on equipment, during transport from factory to user, both the carrier and MixMor must be notified immediately.

When receiving equipment, a check should be made to determine whether all inventoried parts are still in the shipment. Any discrepancy should immediately be reported to both the carrier and MixMor, if claim is to be made.

MixMor mixers do not require the service of a factory engineer upon installation. This service is not included in the price of the unit; therefore, it is to be furnished, it must be agreed upon, in writing, between MixMor and the purchaser.

MixMor warranty becomes void if the unit sold is not operated within the rating and mixing service conditions for which it was specifically sold. The purchaser shall take all necessary precautions to eliminate all external destructive conditions, including unusual variable loads affecting the critical speed of the system, severe shock loading, mechanical or thermal overloads and other conditions of which MixMor was not fully advised. The mixer must be installed and maintained in accordance with this service manual.

MixMor must be informed within thirty days, for warranty to cover the mixer in the event of any malfunction during the warranty period.

All personnel directly responsible for operation of equipment must be instructed on proper installation, maintenance and safety procedures.

Design improvements are implemented on a continuous basis. Therefore, we reserve the right to make change without notice. If any questions arise regarding the data or information in this manual, please contact MixMor.

HANDLING INSTRUCTIONS

SAFETY

When handling or working on a MixMor mixer, safety precautions must always be remembered and followed. The proper tools, clothing and methods of handling should be used to prevent any accidents.

This manual lists a number of safety precautions. Follow them. Insist that your employees do the same. Safety precautions and equipment have been developed from past accidents. Follow and use them for your protection.

HANDLING

Do not support or lift the mixer in a manner, which could create excessive stress on parts or shaft extensions. Never allow shafting to support any weight of the drive assembly. A slightly bent shaft will cause extreme mixer vibration. Support the mixer with a lifting sling to prevent damaging of any external mixer parts. Handle the mixer shaft carefully and always place it in a horizontal position, supporting it at several points.

INSTALLATION INSTRUCTIONS

STORAGE

If installation of the mixer and/or operation is to be delayed for more than one month after factory shipment, special rust preventative precautions should be taken. The precautions may be taken by the user or by the factory if full information concerning storage conditions is provided at the time of ordering. When prolonged storage is unavoidable, it should be indoors and preferable in a dry environment having a relatively constant temperature to avoid condensation problems. Always store the mixer shaft in a horizontal position, supporting it at several points.

LOCATION

The mounting location of the mixer has a definite effect on the flow pattern within the tank. The recommended location has been made with regard to your particular application and should be carefully followed to obtain optimum results.

MOUNTING

Securely bolt down the mixer to its foundation using proper size bolts, which will fit mounting holes. Bolts should be SAE Grade 5 or equivalent.

GEAR REDUCER

MixMor F Series drives are filled with oil from the factory. Consult the sticker adjacent to the fill plug to determine the type of lubricant installed at the factory. Standard lubricant is ISO VG220 mineral-based oil. Refer to the Gear Reducer Lubrication instructions for additional information (pages no. 9 thru 11). Mixers with motor frame sizes 320TC thru 360TC utilize an automatic pressure lubricator for the input assembly bearing, which must be installed and activated prior to start-up. Refer to Gear Reducer Lubrication instructions (pages 14 thru 16).

FLEXIBLE COUPLING

The mixer uses a flexible coupling to connect the motor output shaft to the gear reducer input shaft. After start-up, the mixers that utilize foot-mounted motors should be run until the operating temperature stabilizes. Coupling alignment should then be checked and any necessary corrections made. It is good to check the alignment, once more, after operating under a load for two or three weeks. Refer to page 15.

MIXER SHAFT – Refer to manual front page for supplied coupling design.

Flange Coupling Design

Refer to drawing no. 05-08505, page 4. Handle the shaft carefully and always place it in a horizontal position, supporting it at several points. Slide the tapered end of the shaft (12) through the mixer baseplate or flange and into the flange coupling (10). Insert key (11) into the shaft and coupling keyway. Place the keeper plate (6) into the recess in the flange coupling and tighten socket flat head cap screw (13) to the recommended torque shown on the drawing. Tighten socket head set screw (9). Check the coupling rabbet faces for nicks or burrs. Raise the mixer shaft and tighten hex head cap screw (8) to the recommended torque.

Hollow Shaft Design

Refer to drawing no. 05-47924, page 6. Handle the shaft carefully and always place it in a horizontal position, supporting it at several points. Slide the shaft (4) through the mixer baseplate (3) and into the gear reducer hollow bore shaft (2) until the machined step or thrust collar is against the bottom of the hollow shaft. Align the shaft keyways and insert key (6) into the hollow shaft. Place the keeper plate (5) on the top of the hollow shaft and tighten socket flat head cap screw (1) to the recommended torque shown on the drawing. Replace the hollow shaft cover.

MIXER SHAFT ASSEMBLY
Dwg. No. 05-47924

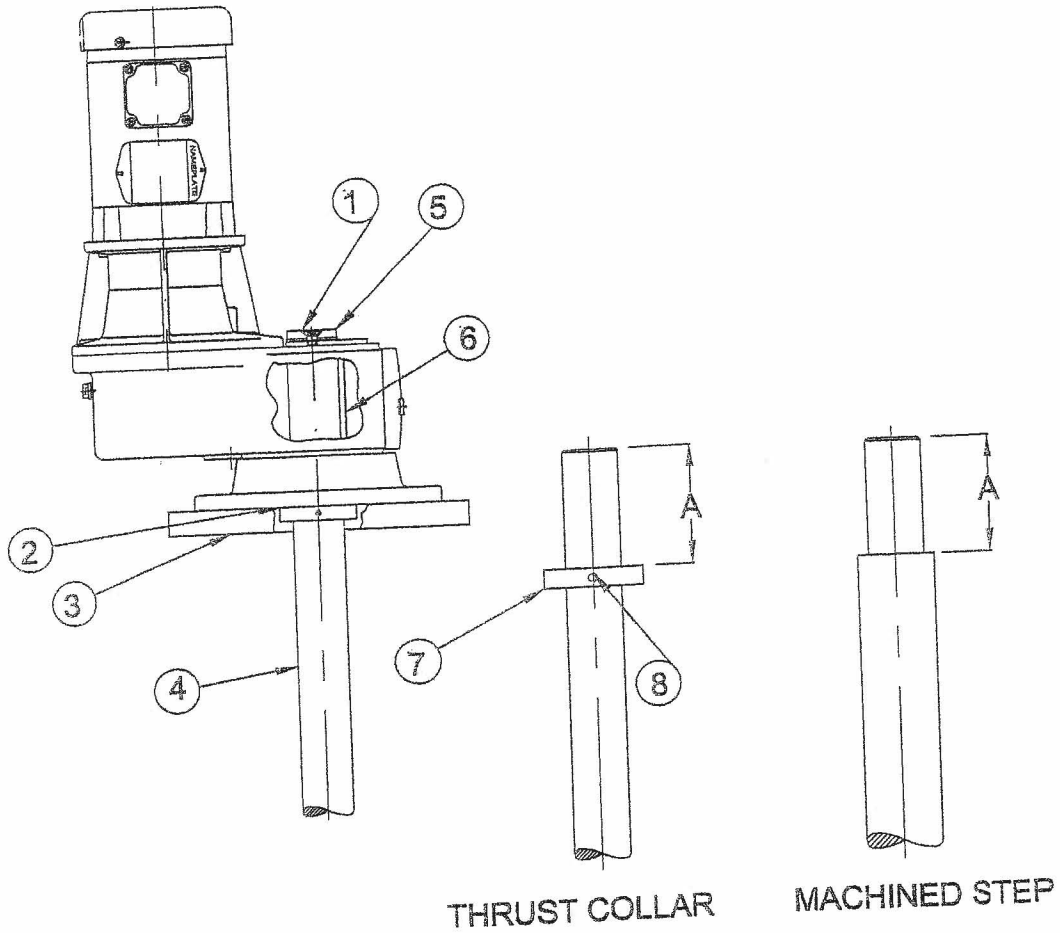

PART NO.	DESCRIPTION
1	SOCKET HEAD FLAT SCREW
2	HOLLOW BORE SHAFT
3	BASEPLATE
4	MIXER SHAFT
5	KEEPER PLATE
6	KEY
7	THRUST COLLAR
8	SOCKET HEAD SET SCREW (2)

DRIVE SIZE	TORQUE FT./LBS.
F22	170
F32	170
F42	170
F52	300
F62	300
F72	300
F82	485

DRIVE SIZE	'A' DIM.
F22	8.07"
F32	9.57"
F42	11.30"
F52	13.58"
F62	17.08"
F72	18.66"
F82	21.77"

PBT4 & VFBT4 IMPELLERS
Dwg. No. 05-47830

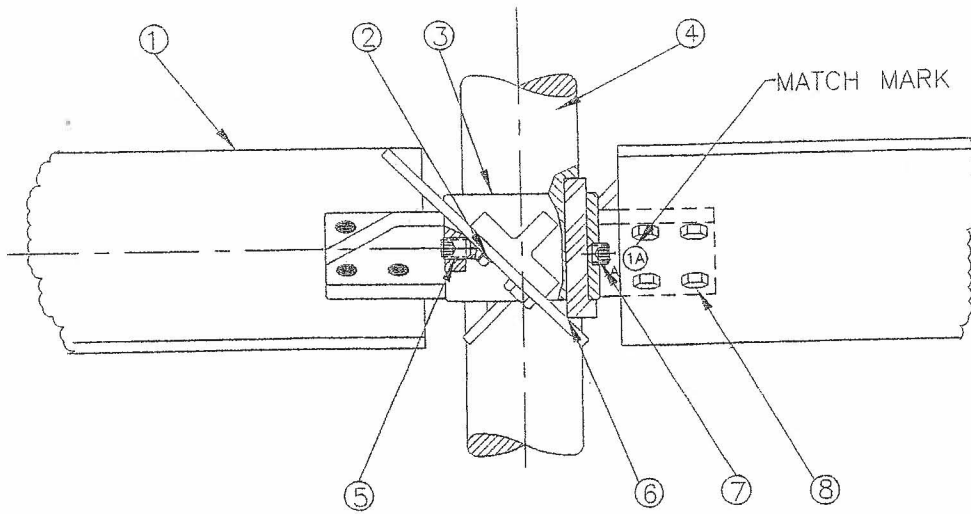

Shafts may be spot drill for larger impeller set screws

PART NO.	DESCRIPTION	PART NO.	DESCRIPTION
1	BLADE	5	SOCKET HEAD SET SCREW
2	LOCK WASHER	6	HOOK KEY
3	HUB	7	SOCKET HEAD SET SCREW
4	SHAFT	8	HEX HEAD CAP SCREW

FM3, FM4, FM3W & FM4W IMPELLERS
Dwg. No. 05-47831

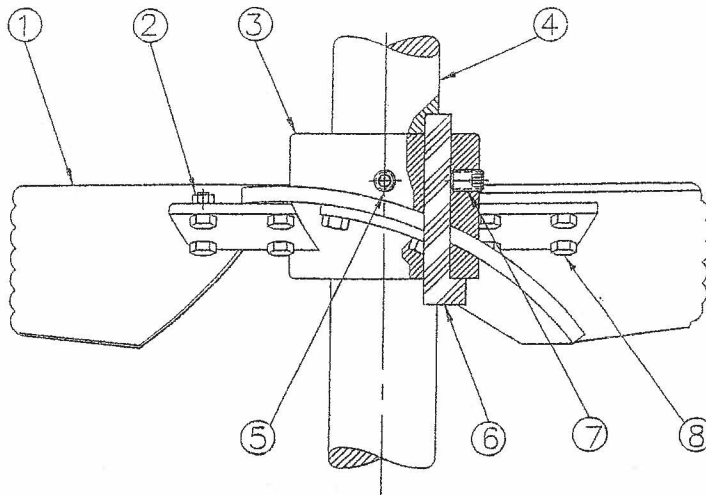

Shafts may be spot drill for larger impeller set screws

PART NO.	DESCRIPTION	PART NO.	DESCRIPTION
1	BLADE	5	SOCKET HEAD SET SCREW
2	HEX NUT	6	HOOK KEY
3	HUB	7	SOCKET HEAD SET SCREW
4	SHAFT	8	HEX HEAD CAP SCREW

MODEL TO, BASEPLATE BEARING AND PARTS

Dwg. No. 05-01605

GENERAL INFORMATION

This model mounts on a square baseplate. Depending upon drive size and mixer shaft design, many mixer baseplates incorporate a heavy-duty self-aligning ball bearing for additional shaft support. The following lubrication instructions apply if your baseplate has a bearing mounted onto it.

BASEPLATE BEARING LUBRICATION

The bearing should contain as much grease as practical, since a full bearing with consequent slight leakage is the best protection against entrance of foreign material. When establishing a relubrication schedule, note that a small amount of grease at frequent intervals is preferable to a large amount at infrequent intervals. A good starting point to establish a relubrication schedule is to relubricate the bearing weekly. If the mixer is operated in a clean, dry environment, the bearings will have to be relubricated less frequently.

Abnormal bearing temperatures may indicate faulty lubrication. Normal temperatures may range from "cool to warm to the touch" up to a point "too hot to touch for more than a few seconds", depending upon the bearing size and surrounding conditions. High temperature with no grease showing at the seals, particularly if the bearing seems noisy, usually indicates too little grease. Unusually high temperature accompanied by excessive leakage of grease indicates too much grease. Normal temperature and a slight showing of grease at the seals indicates proper lubrication.

Many ordinary cup greases are not suitable for lubrication. The bearing has been lubricated at the factory with No. 2 consistency lithium base grease, which is suitable for normal operating conditions. Relubricate with lithium base grease or grease, which is compatible with original lubricant and suitable for ball bearing service. In unusual or doubtful cases, consult with a reputable grease manufacturer.

MODEL TO PARTS
Dwg. No. 05-01605

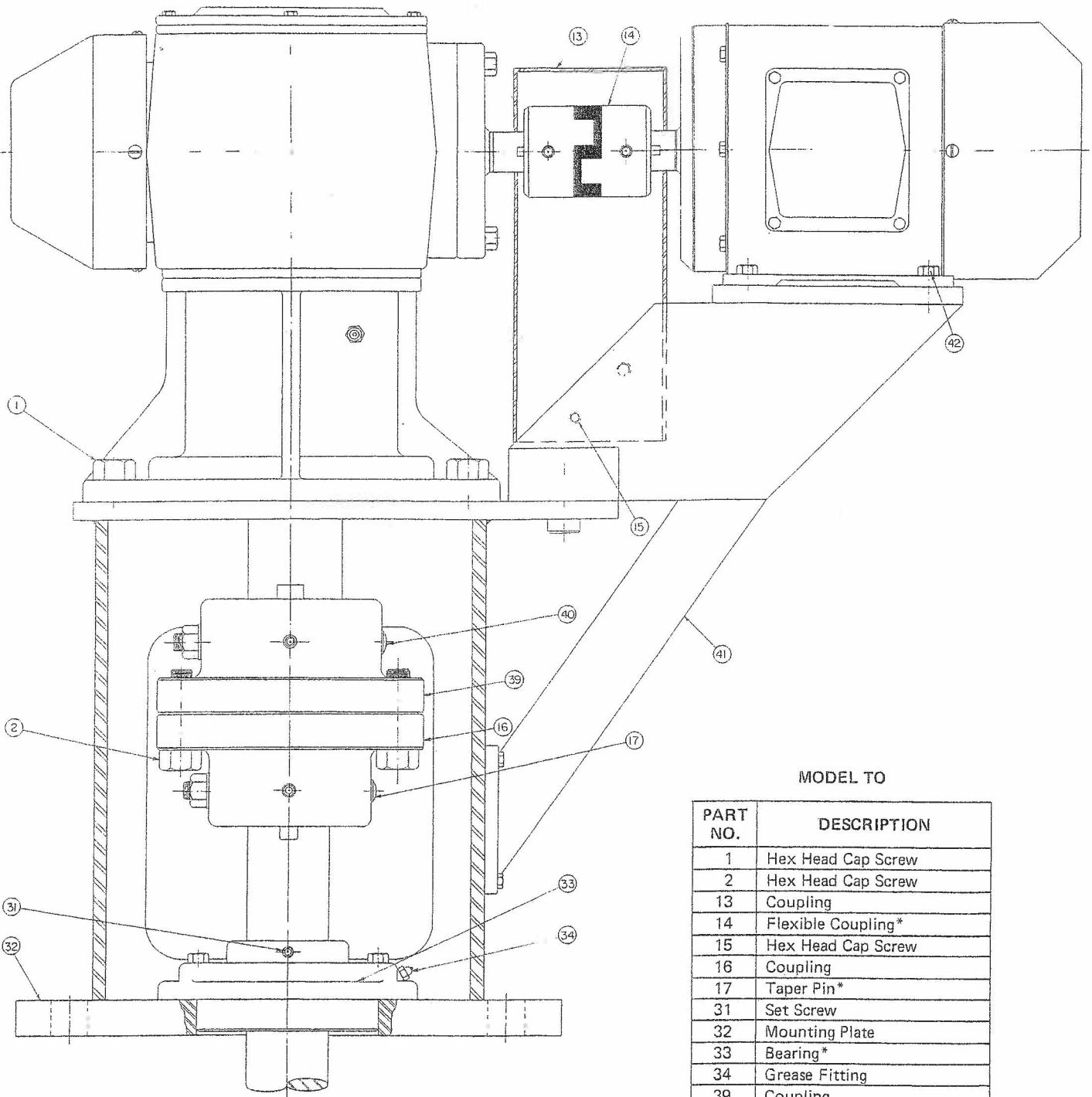

MODEL TO

PART NO.	DESCRIPTION
1	Hex Head Cap Screw
2	Hex Head Cap Screw
13	Coupling
14	Flexible Coupling*
15	Hex Head Cap Screw
16	Coupling
17	Taper Pin*
31	Set Screw
32	Mounting Plate
33	Bearing*
34	Grease Fitting
39	Coupling
40	Taper Pin*
41	Baseplate Support
42	Hex Bolt

*Recommended Spare Parts

OPEN TANK-PLATE MOUNTED

NOTE: Refer to Dwg. No. 05-08505, page 4,
for current flange coupling design.

MODEL TCL AND TC, STUFFING BOX AND PARTS

GENERAL INFORMATION

The purpose of a stuffing box packing is to limit leakage to a practical level and not to stop leakage completely. If the gland is tightened to prevent all leakage, packing life will be shortened and shaft damage will occur. The stuffing box START-UP instructions should be carefully followed for long packing and shaft life.

The packing type furnished with the mixer is specified on the certified drawing. If the furnished packing is not satisfactory for the service conditions, it should be replaced.

LUBRICATION

The stuffing box is shipped without lubricant because of Federal regulations and the danger of using a lubricant that may contaminate the product. The stuffing box is normally furnished with a grease fitting and lantern ring for intermittent lubrication of the packing.

START-UP INSTRUCTIONS – Refer to Dwgs. No. 05-01604 and 05-01606

Prior to initial operation, the following procedure should be used to assure a long seal life.

1. Tighten the gland screws (35) to "finger tightness".
2. Start the mixer and run it until the stuffing box has reached a constant operating temperature. Stop the mixer and tighten opposite screws (35). Note: When tightening the screws, be careful to avoid cocking the follower (36). Even tightening of the follower will seat the packing (37) while it is warm and pliable.
3. Loosen gland screws (35) to finger tightness and re-start the mixer. Leakage may be excessive but do not tighten the screws for the first 20 to 30 minutes.
4. If leakage is excessive after this initial run-in period, adjust the follower by tightening the screws evenly, one flat or a sixth of a turn at a time. This should be done every 30 minutes until leakage is reduced to a normal level.
5. Adjustments must always be done gradually and held to a minimum tightness. Although this procedure may take several hours; it will pay dividends in increase packing and shaft life.

REPACKING PROCEDURE

1. Remove the follower (36), all packing (37) and lantern ring (38) (Model TC only). Carefully avoid scoring the shaft with the packing hook or removal tool.
2. Inspect the shaft and lantern ring (38). Lantern ring, lubrication channel and holes must be free of packing and dirt. Minor shaft wear should be worked smooth. Where excessive wear exists, the shaft should be built-up and re-machined to give a smooth finish or it should be replaced. Clean stuffing box thoroughly, checking to insure the lubrication holes are free and clear.
3. The location of the lantern ring (38) should be predetermined for proper alignment between lubrication holes and grease lines or fittings.
4. Insert first ring of packing (37) into the box. Install a split spacer (preferably of wood) into the box against packing so that packing ring is firmly seated and spread to make a good seal against the inside walls of the box and the shaft. When tightening the follower, pull it up evenly so each ring will be packed squarely into the box, assuring a good seal. Repeat this procedure for each ring. The individual packing joints must be staggered at 90°.
5. After the box has been completely packed, replace the follower, tightening the screws (35) to finger tightness.
6. Start the mixer and run it until the stuffing box has reached a constant operating temperature. Stop the mixer and tighten the screws. When tightening, be careful to avoid cocking the follower. Even tightening of the follower will seat the packing (37) while it is warm and pliable.
7. Again, loosen the screws to finger tightness. Do not tighten the screws for the first 20 to 30 minutes, even though leakage may be excessive.
8. If leakage is excessive after this initial run-in period adjust the follower by tightening the screws. This should be done every 30 minutes until leakage is reduced to a normal level.
9. Adjustments must always be done gradually, over several hours and held to a minimum tightness to increase packing life.

MODEL TCL PARTS
Dwg. No. 05-01604

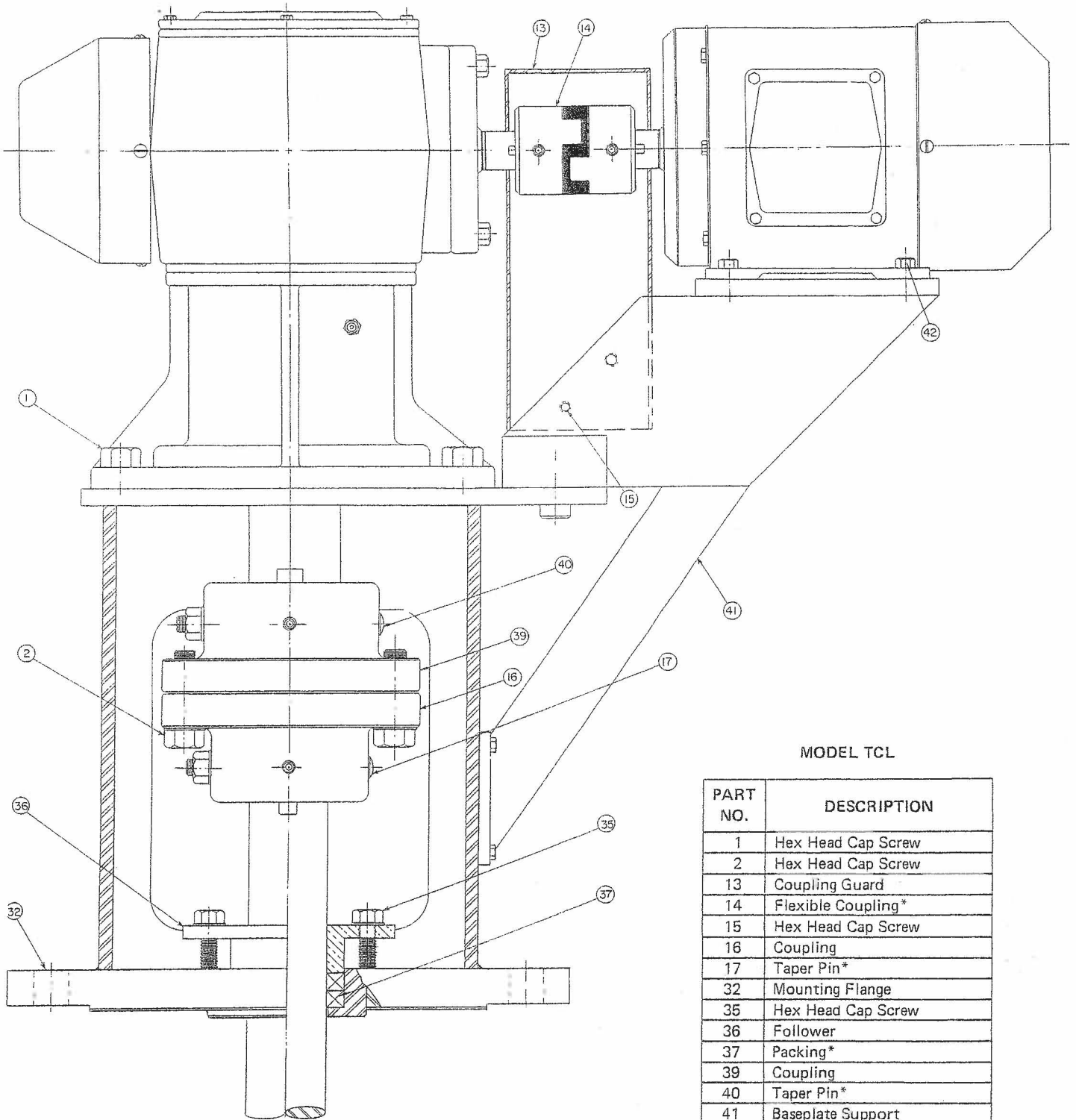

MODEL TCL

PART NO.	DESCRIPTION
1	Hex Head Cap Screw
2	Hex Head Cap Screw
13	Coupling Guard
14	Flexible Coupling*
15	Hex Head Cap Screw
16	Coupling
17	Taper Pin*
32	Mounting Flange
35	Hex Head Cap Screw
36	Follower
37	Packing*
39	Coupling
40	Taper Pin*
41	Baseplate Support
42	Hex Bolt

*Recommended Spare Parts

NOTE: Refer to Dwg. No. 05-08505, page 4,
for current flange coupling design.

MODEL TC PARTS
Dwg. No. 05-01606

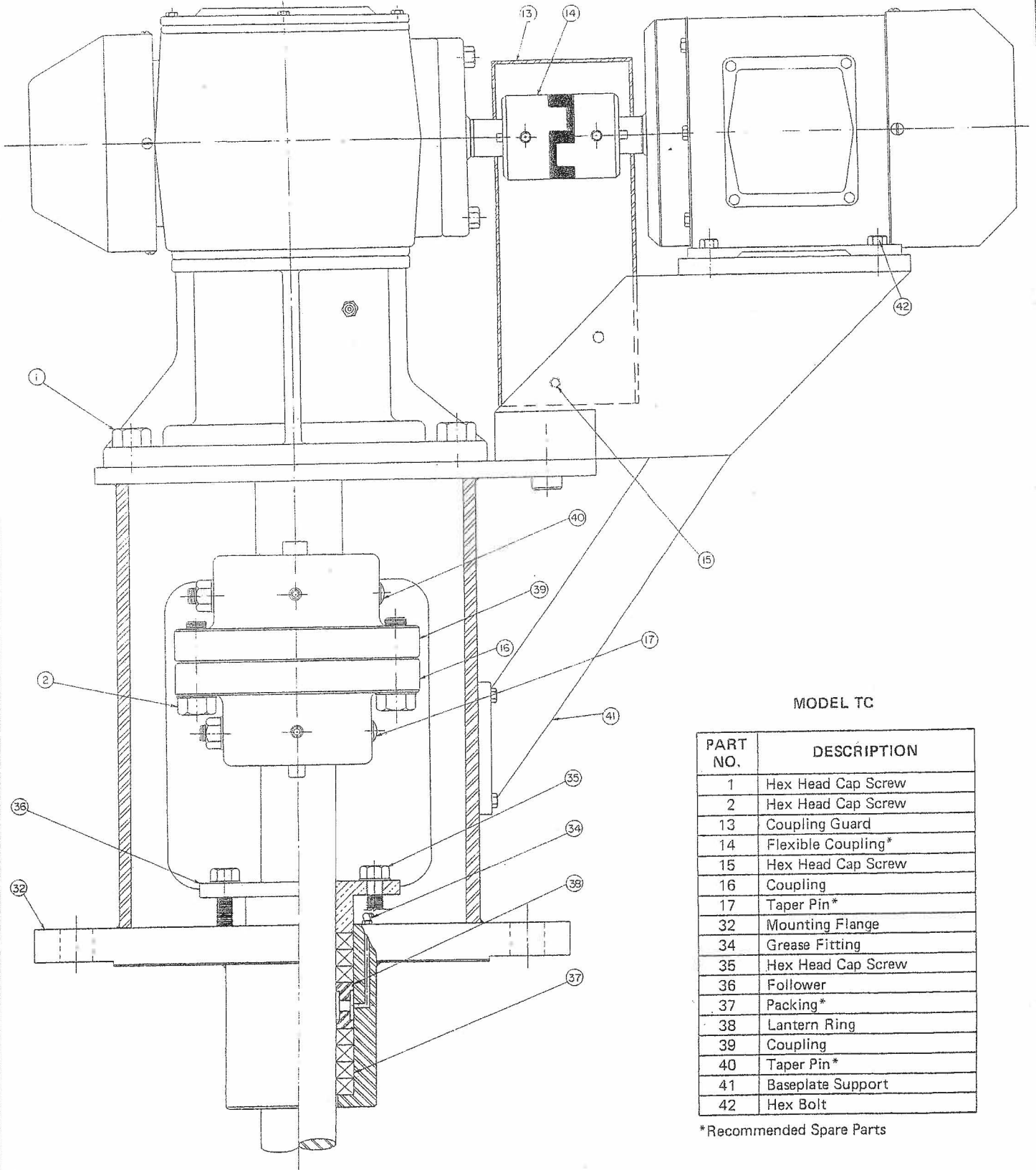

MODEL TC

PART NO.	DESCRIPTION
1	Hex Head Cap Screw
2	Hex Head Cap Screw
13	Coupling Guard
14	Flexible Coupling*
15	Hex Head Cap Screw
16	Coupling
17	Taper Pin*
32	Mounting Flange
34	Grease Fitting
35	Hex Head Cap Screw
36	Follower
37	Packing*
38	Lantern Ring
39	Coupling
40	Taper Pin*
41	Baseplate Support
42	Hex Bolt

*Recommended Spare Parts

NOTE: Refer to Dwg. No. 05-08505, page 4,
for current flange coupling design.

HIGH PRESSURE STUFFING BOX
7 RINGS PACKING

STEADY BEARING

INSTALLATION – Refer to Dwg. No. 05-09794

The steady bearing must be centered on the mixer shaft's axis of rotation. To assure that the steady bearing is properly located and to minimize bearing preload, it must be installed after the mixer is mounted onto the tank and after the shaft is installed.

To find that shaft's axis of rotation, attach a marker that will contact that tank bottom to the end of the shaft. Remove the motor fan cover and rotate the motor fan. This will draw a circle on the tank bottom. Install the steady bearing in the center of this circle.

The shaft runout will differ depending upon the shaft length and diameter.

Dwg. No. 05-09794

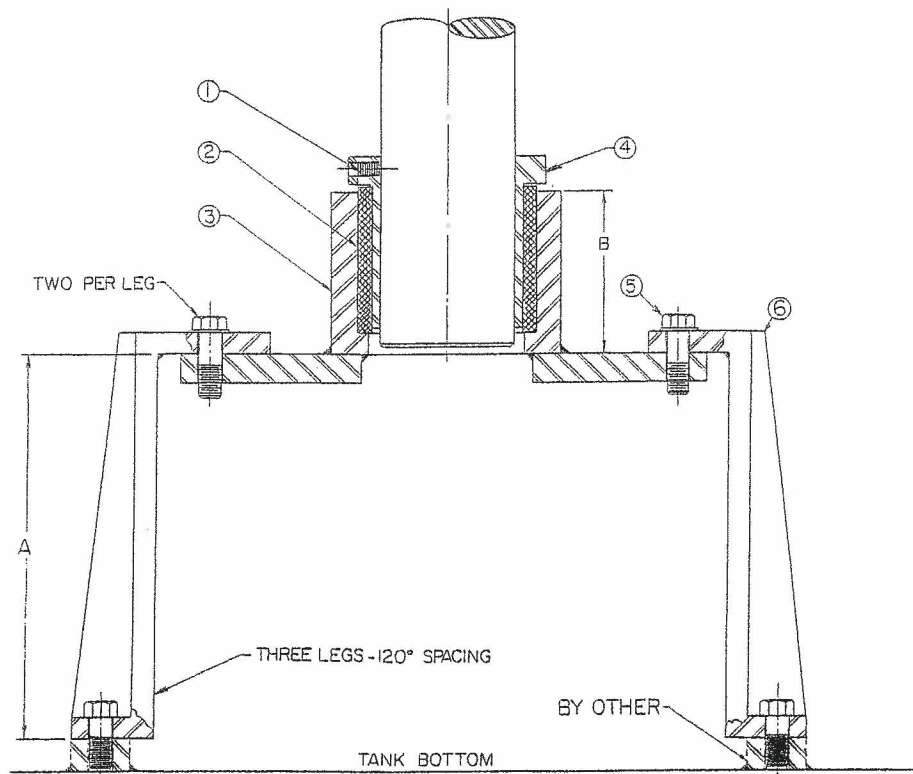

PART NO.	DESCRIPTION
1	SOCKET HEAD SET SCREW
2	BUSHING *
3	CARTRIDGE
4	SHAFT WEAR SLEEVE *
5	HEX HEAD CAP SCREW
6	STAND

* Recommended Spare Parts

SHAFT DIA.	A	B
2-2¼"	6"	3"
2½"-3"	7"	3½"
3½"-4"	8"	4½"
4½"-5"	8½"	5½"
5½"-6"	9"	6½"

Dimensions are approximate

GEAR REDUCER LUBRICATION

FILL LEVEL & DRAIN PLUGS

The drain plugs are metric socket head cap screws. They will be located at the lowest part of the gearbox for ease of draining. The fill level plug is a hex head cap screw. It will be located between the Autovent and drain plug. Both types of plugs will have gaskets included to prevent oil from leaking.

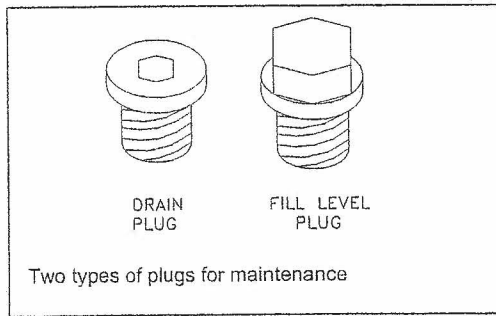

LUBRICANT

All NORD reducers are shipped from the factory properly filled with lubricant and all plugs are installed according to the mounting position given on the reducer nametag. Acceptable oil fill level is within 1/2 inch of the bottom of the fill plug threads.

OPERATION AND MAINTENANCE CHECKLIST

1. Operate the equipment as it was intended to be operated
2. Do not overload.
3. Run at correct speed.
4. Maintain lubricant in good condition and at proper level.
5. Dispose of used lubricant in accordance with applicable laws and regulations.
6. Apply proper maintenance to attached equipment at prescribed intervals recommended by the manufacturer.
7. Perform periodic maintenance of the gear drive as recommended by NORD.

LUBRICATION CAPACITY

DRIVE SIZE	QUARTS
F22	2.11
F32	4.33
F42	5.71
F52	9.30
F62	18.50
F72	28.50
F82	43.30

AUTOVENT PLUG

The Autovent plug is brass in color and will be located at the highest point on the gearbox. It operates like a check-valve to allow the reducer to relieve internal pressure while preventing lubricant contamination during cooling. A spring presses a ball or plunger against a machined orifice until pressure exceeds 2 psi. Above 2 psi the air is allowed to escape depressurizing the gearcase. When internal pressure drops below 2 psi, the autovent re-seals closing the unit to the outside environment. After shutdown, the reducer cools along with the air inside the reducer. The unit will temporarily maintain a slight vacuum until normalization occurs. NORD Gear supplies an Autovent as a standard feature.

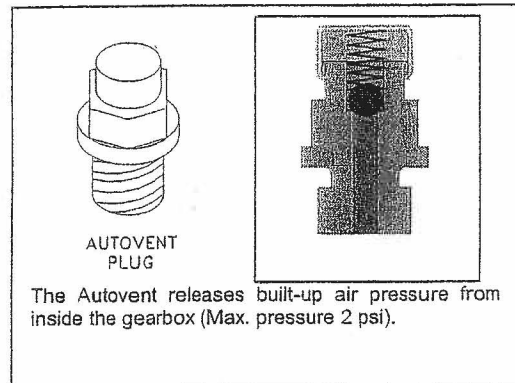

MAINTENANCE

Mineral oil should be changed every 10,000 hours or after two years. For synthetic oils, the lubricant should be changed every 20,000 hours or after four years. In case of extreme operating conditions (e.g. high humidity, aggressive environment or large temperature variations), shorter intervals between changes are recommended. If in doubt about the intervals, consult MixMor or your lubricant supplier.

OIL SPECIFICATIONS

MixMor L Series drives are filled with oil from the factory. Consult the sticker adjacent to the fill plug to determine the type of lubricant installed at the factory. Standard lubricant is ISO VG220 mineral-based oil. However, some units have special lubricants designed to operate in certain environments or to extend the service life of the lubricant. If in doubt about which lubricant is needed, consult MixMor.

STANDARD OIL – ISO VG220

Ambient Temperature	Formulation	Oil Manufacturer	Oil Brand Name	Origin of Gearbox Assembly
20 to 104°F (-5 to 40°C)	Mineral	Texaco	Meropa 220	NORD USA
20 to 104°F (-5 to 40°C)	Mineral	Shell	Omala EP 220	NORD Canada

OPTIONAL LUBRICANTS

Ambient Temperature	Formulation	Oil Manufacturer	Oil Brand Name	Origin of Gearbox Assembly
14 to 176°F (-10 to 80°C)	Synthetic	Texaco	Pinnacle EP680	NORD USA
14 to 176°F (-10 to 80°C)	Synthetic	Shell	Omala HD 680	NORD Canada
-13 to 140°F (-25 to 60°C)	Synthetic	Texaco	Pinnacle EP220	NORD USA
-13 to 140°F (-25 to 60°C)	Synthetic	Shell	Omala HD 220	NORD Canada
-40 to 50°F (-40 to 10°C)	Synthetic	Texaco	Pinnacle EP32	NORD USA
-40 to 50°F (-40 to 10°C)	Synthetic	Shell	Omala HD 32	NORD Canada
20 to 104°F (-5 to 40°C)	Food Grade	Chevron	FM ISO 220	NORD USA
20 to 104°F (-5 to 40°C)	Synthetic Food Grade	OilJAX	Magnaplate 85W140-FG	NORD Canada
5 to 125°F (-20 to 50°C)	Fluid Grease	Mobil	Mobilux EP023	NORD USA
-30 to 140°F (-35 to 60°C)	Synthetic Fluid Grease	Mobil	Mobilith SHC 007	NORD USA
-30 to 140°F (-35 to 60°C)	Synthetic Fluid Grease	Shell	Tivela compound A	NORD Canada

STANDARD BEARING GREASE – NLGI 2EP lithium

Ambient Temperature	Formulation	Grease Manufacturer	Grease Brand Name	Origin of Gearbox Assembly
-20 to 140°F (-30 to 60°C)	Mineral	Texaco	Multifak EP2	NORD USA
-20 to 140°F (-30 to 60°C)	Mineral	Shell	Cybernia RAC3	NORD Canada

OPTIONAL BEARING GREASE

Ambient Temperature	Formulation	Grease Manufacturer	Grease Brand Name	Origin of Gearbox Assembly
-58 to 230°F (-50 to 110°C)	Synthetic	Texaco	Starfak 2202	NORD USA
-58 to 230°F (-50 to 110°C)	Synthetic	Shell	Aero Shell	NORD Canada
5 to 230°F (-20 to 110°C)	Food Grade	Lubriplate	SIF 1	NORD USA

AUTOMATIC LUBRICATOR

This lubricator is used only on input assembly no. 05-47755, for motor frame sizes 320TC thru 360TC, refer to page 20 for assembly details.

Principle of Operation

After tightening the plastic activating screw, the Zinc-Molybdenum pellet drops into the Citric Acid electrolyte. The chemical reaction builds up pressure that causes the piston to move forward. The lubricant is continuously injected into the lubrication point. At the end of the lubrication period, the discharge indicator cap becomes clearly visible indicating the lubricant has been fully discharged. The lubrication period is determined and defined by the color of the activating screw.

For the bearings used in NORD Gear products, a 12 month lubrication period is standard, indicated by a gray activating screw. This applies for an average operating time of 8 hours/day. For longer operating times, the replacement interval decreases to 6 months. Lubrication canisters are also available for cold temperature applications. Contact NORD Gear for more information.

Assembly Instructions

1. Remove the plug from the male connecting thread.
2. Screw male fitting into bearing housing within Input Adapter.
3. Insert activating screw into end of canister. Tighten until the ring-eyellet breaks off.
4. Replace every twelve months.

Perma Classic Specifications

Standard Lubricant	Klüber Isoflex Topas NB52 (synthetic)
Lubricant Volume	120 mL (4 oz.)
Operating Temperature Range	0°C to 40°C (32°F to 104°F)
Discharge Time	12 months at 25°C (77°F)
Operating Position	Independent of mounting position, operates even under water.
Male Connecting Thread	1/4" NPT

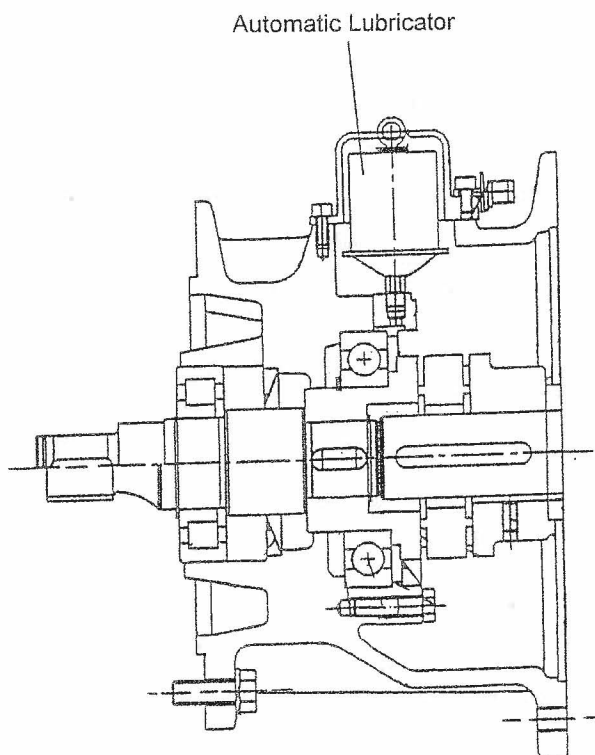
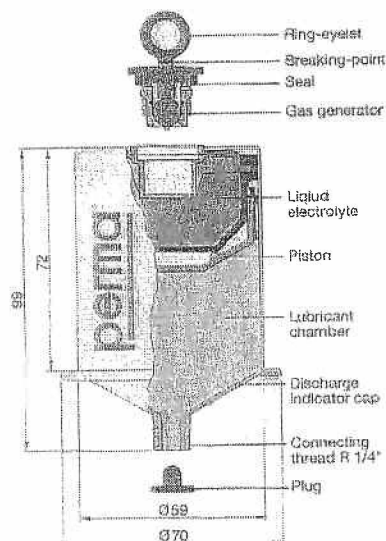
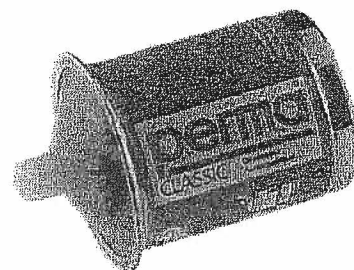

Input Assembly No. 05-47755

START-UP INSTRUCTIONS

When starting up any new piece of equipment, it is wise to proceed cautiously. Even though the best installation practices are followed, the possibilities of errors or omissions always exist. MixMor recommends that before the initial start-up, the following checklist should be followed.

1. Has all accessory equipment such as: breathers, level indicators, pressure gauges, switches, etc., been mounted? It is often necessary to box these items separately to prevent damage or loss in shipment.
2. Are mounting bolts tight? Check all external bolts, screws, accessories, etc., to make sure they have not become loose in shipping and handling.
3. Have all couplings been mounted to shaft extensions correctly with keys and fasteners in place?
4. Have bearings been greased?
5. Have couplings been tightened properly? Have necessary guards and safety devices been installed at all hazardous locations?
6. Has the gear reducer been filled with oil as outlined in the GEAR REDUCER LUBRICATION section? Before start-up, all MixMor mixer drives must be filled with the type and grade of oil specified.
7. Have required electrical connections been made? Units should be wired in accordance with motor manufacturers' wiring diagram on the motor.
8. Have required piping connections been made?
9. Have mixer shaft seal instructions been followed?

Mixers are test run at the factory. However, during start-up, the following procedures are recommended:

1. If the reducer is equipped with heaters for cold temperature operation, turn on heaters and allow to rise to at least 65°F.
2. Start unit slowly under as light a load as possible. Check rotation of the shaft against rotation arrow on the mixer housing. If necessary, reverse electrical leads on motors to have shaft rotation conform to direction shown on mixer.
3. Prime mover electrical starting equipment should be arranged to start unit as slowly as possible to avoid severe impact loads.
4. As the mixer is brought up to normal operating speed, it should be checked continuously for unusual sounds, excessive vibrations, excessive heat or leakage. If any of these develop, the unit should be shut down immediately and the cause determined and corrected. The operating temperature of the mixer at the hottest point should not exceed 200°F.
5. If possible, the mixer should be operated under a light load (approximately half-load) for one or two days to allow final breaking-in of gears. After this period, the unit can be operated under normal load.
6. After the first 48 hours of operation, all external housing and mounting fasteners should be checked for tightness. Loose fasteners can cause alignment problems and excessive wear.
7. The alignment of the flexible coupling should be checked and any necessary corrections made. It is good practice to check the alignment once more after operating under a load for two or three weeks.

GEAR REDUCER

PREVENTATIVE MAINTENANCE

Keep the shafts and dip stick/vent clean to prevent foreign particles from entering the shaft seals or gear case, which could cause premature wear. Never paint the vent plug. Check coupling set screws and all fasteners for tightness. Loose fasteners will cause alignment problems and excessive wear. Check end play in shaft. Noticeable movement might indicate service or parts replacement. The lubrication instructions should always be carefully followed. Inspect the reducer periodically for oil leaks. When oil seals are new, a small amount of lubricant leakage may appear until the seals are seated.

Proper maintenance will result in years of trouble-free performance and an extended life.

TROUBLE SHOOTING

It is advisable to periodically inspect the gear reducer for signs of wear. Spare or replacement parts can often be ordered and obtained before disassembly is necessary, thus minimizing downtime. Most of the following observations can be visually inspected without disassembly and may, in some cases, require repair work.

CHECKLIST		
OBSERVATION	POSSIBLE SOURCE	ACTION
VIBRATION	1) Loose hardware 2) Bearing failure 3) Flexible coupling alignment 4) Foreign particles in bearings and gears	Be certain all external housing and mounting fasteners are Tight Replace bearings Check alignment of high-speed flexible coupling and condition Of flexible member. Foreign particles will cause excessive wear. Take steps to Prevent entrance of particles. Thoroughly flush drive and Refill with new oil. Modify maintenance schedule to increase Frequency of oil changes.
OVERHEATING	1) Incorrect oil 2) Oil level 3) Oil condition 4) Amount of grease in bearing 5) Wrong type of bearing grease 6) Bearing adjustment 7) Breather 8) Overloaded	Refer to Lubricating Instructions for correct oil. Flush drive And refill with correct oil. Check oil level and add or drain to correct level Check to see if oil is oxidized, dirty, or of high sludge content. Change oil. Refer to Lubrication Instructions. Make sure bearing does not have An insufficient or excessive amount of grease in it. Refer to Lubrication Instructions. If incorrect grease has been used, Flush housing with grease. Adjustable tapered bearings must be set to proper axial play. All Shafts should turn freely when not under load Breather must be free of any obstruction. Clean breather as Required. Check mixer speed and impeller diameter against certified drawing. Has the specific gravity and/or viscosity of the product increased? Inspect for material build-up on impeller. Check shaft rotation Against rotation arrow.

CHECKLIST

OBSERVATION	POSSIBLE SOURCE	ACTION
NOISE	<ol style="list-style-type: none"> 1) Bearing failure 2) Rust inside drive 3) Extended shut-down or improper storage 4) Overloaded 5) Refer to VIBRATION, Source No.'s 3 & 4 6) Refer to OVERHEATING, Source No.'s 1,2,3,4,5 & 6 	<p>Replace bearings</p> <p>Rust can be caused by entrance of water or humidity. Flush And thoroughly clean drive. Take steps to prevent further Entrance of water and use a lubricant with good rust-inhibiting Properties.</p> <p>When drives are not properly prepared for extended shut-Down or storage in a moist atmosphere or a temperature Condition which will cause condensation, destructive rusting Of bearing, gears and shafts/seals will take place. Clean and Replace parts as required.</p> <p>Overloading can cause excessive separation of gear teeth And loud operation. Refer to OVERHEATING, Source No. 8</p>
OIL LEAKING	<ol style="list-style-type: none"> 1) Worn oil seals 2) Oil in drywell leaking at output shaft 3) Plugged breather 4) Gear case/ cap joints 5) Drain plugs, sight glasses or pipe fittings 	<p>Replace defective seals</p> <p>During storage or when mixer is being installed, with oil in the Reducer, oil can flow over the drywell and through the output Shaft seal. Check if oil level is too high. Remove lower Bearing assembly and drain drywell.</p> <p>Breather must be free of any obstructions. Clean breather as Required.</p> <p>Tighten fasteners. If this does not stop leakage, remove covers or caps, clean surfaces and replace gaskets or apply new sealing compound.</p> <p>Remove and clean all fittings. Apply a pipe joint sealant and re-install fittings.</p>

FLEXIBLE COUPLINGS

Depending on the size of the input adapter to the gearbox, NORD Gear supplies two styles of couplings - BoWex® (gear tooth) and Rotex® (jaw) couplings.

BoWex® Couplings

NORD C-face adapter input shafts have a machined spline on the end. NORD incorporates two styles of BoWex® couplings, the "J" and "M" styles. The "J" style is a one-piece coupling with a metal hub and nylon spline. The "M" style is a two piece coupling - the metal hub and a nylon sleeve. Nylon and steel components allow them to operate in high ambient temperatures without lubrication or maintenance.

- Nylon sleeves resist dirt, moisture, most chemicals and petroleum products
- No lubrication required
- Operating Conditions: -22°F - 195°F (-30°C - 90°C)
- Higher temperature coupling sleeve available up to 250°F (120°C)

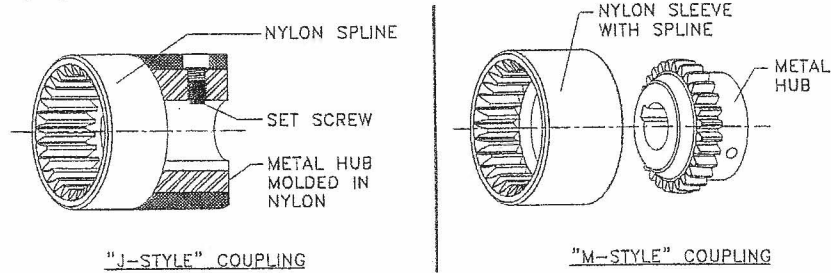

BoWex® Mechanical Ratings

"J" Style

Coupling Type	Available Bore Sizes	Max. Torque	Input
J14	11, 14 mm 5/8 in.	20 Nm 177 lb-in	IEC 63, 71 NEMA 56C
J24	19, 24 mm 5/8, 7/8 in	40 Nm 354 lb-in	IEC 80 NEMA 56C, 140TC
J28	28mm 1 1/8 in	90 Nm 797 lb-in	IEC 100, 112 NEMA 180TC

"M" Style

Coupling Type	Available Bore Sizes	Max. Torque	Input
M38	38 mm 1 1/8, 1 3/8 in.	160 Nm 1,416 lb-in	IEC 132 NEMA 180TC, 210TC
M42	42 mm 1 5/8 in	200 Nm 1,770 lb-in	IEC 160 NEMA 250TC
M48	48 mm 1 7/8 in	280 Nm 2,478 lb-in	IEC 180 NEMA 280TC

Rotex® Couplings

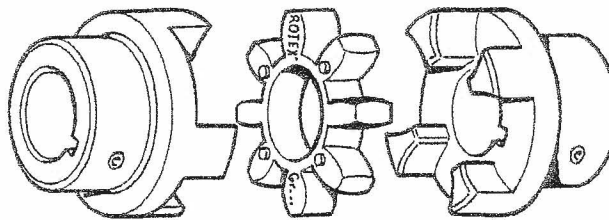

Rotex® Mechanical Ratings

Coupling Type	Available Bore Sizes	Max. Torque	C-Face Inputs	Spider
R48	42, 48 mm 1 5/8, 1 7/8 in	620 Nm 5,487 lb-in	IEC 160, 180 NEMA 250T, 280T	Urethane 92 Shore A Hardness Color: Yellow
R65	60 mm 2 1/8, 2 3/8 in	1,250 Nm 11,063 lb-in	IEC 225 NEMA 320T, 360T	
R90	65, 75, 80 mm 2 1/8, 2 3/8 in	4,800 Nm 42,480 lb-in	IEC 250, 280, 315 NEMA 360T, 400TS, 440TS	

OIL LEAKAGE PROTECTION CHAMBER

The output shaft assembly includes an oil leakage protection chamber, which traps any possible oil leakage through the quadrilip™ seal.

In case of lubricant leakage through the lower seals the lubricant runs over the slinger ring into the protection chamber flange and collects at the lowest point at which an oil indicator is placed. Alternately an oil-sensor can be used or the lubricant can be fed through a relief-pipe in place of the indicator.

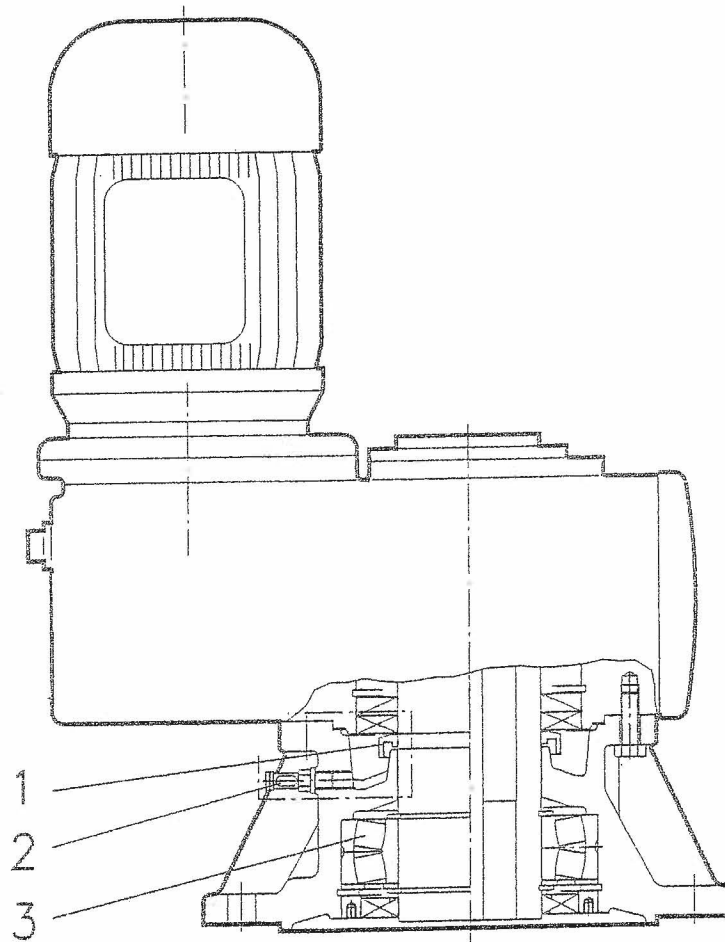

ITEM NO.	DESCRIPTION
1	SLINGER RING
2	OIL-INDICATOR
3	SPHERICAL ROLLER BEARING

DRIVE SERIES F22 thru F52 PARTS

Dwg. No. 05-47925

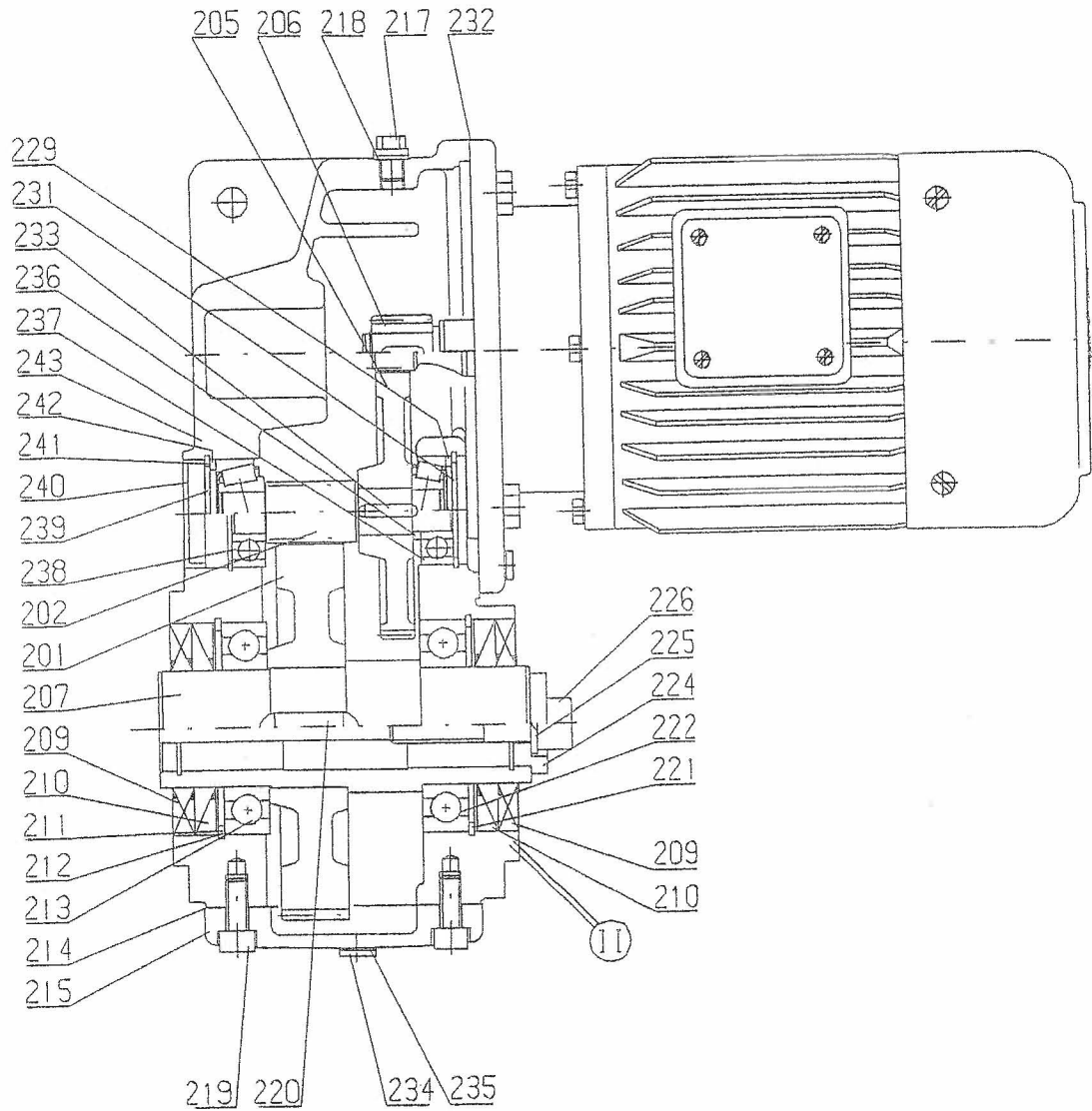

PART NO.	DESCRIPTION	PART NO.	DESCRIPTION	PART NO.	DESCRIPTION	PART NO.	DESCRIPTION
201	DRIVEN GEAR	213	BALL BEARING +	224	WASHER	236	SUPPORTING DISK
202	PINION SHAFT	214	SEAL +	225	WASHER	237	PINION SHAFT BEARING +
205	DRIVING GEAR	215	GEAR CASE COVER	226	SOCKET HEAD SCREW	238	PINION SHAFT BEARING +
206	DRIVING PINION	217	VENT PLUG	230	GEAR BOX COVER	239	RETAINING RING +
207	OUTPUT SHAFT/HOLLOW	218	SEAL +	231	RETAINING RING +	240	LOCKING CAP
209	SHAFT SEAL (2) +	219	SOCKET HEAD SCREW	232	SEAL +	241	SHIM +
210	SHAFT SEAL (2) +	220	KEY	233	KEY	242	SUPPORTING DISK
211	RETAINING RING +	221	RETAINING RING +	234	DRAIN PLUG	243	GEAR CASE
212	SHIM +	222	BALL BEARING +	235	SEAL +		

+ RECOMMENDED SPARE PARTS

DRIVE SERIES F62 thru F82 PARTS

Dwg. No. 05-48004

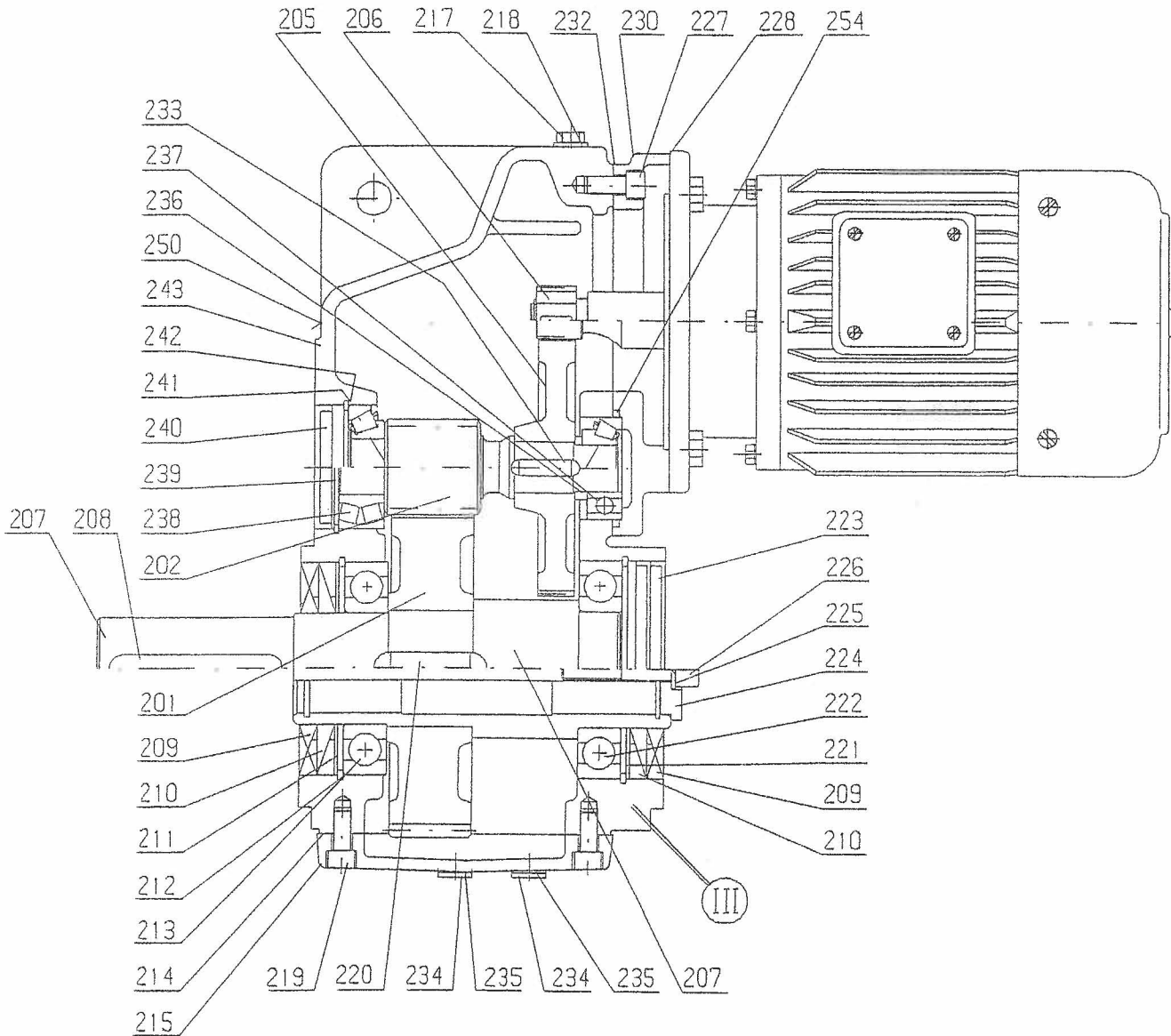

PART NO.	DESCRIPTION	PART NO.	DESCRIPTION	PART NO.	DESCRIPTION	PART NO.	DESCRIPTION
201	DRIVEN GEAR	213	BALL BEARING +	224	WASHER	236	SUPPORTING DISK
202	PINION SHAFT	214	SEAL +	225	WASHER	237	PINION SHAFT BEARING +
205	DRIVING GEAR	215	GEAR CASE COVER	226	SOCKET HEAD SCREW	238	PINION SHAFT BEARING +
206	DRIVING PINION	217	VENT PLUG	227	SOCKET HEAD SCREW	239	RETAINING RING +
207	OUTPUT SHAFT/HOLLOW	218	SEAL +	228	SEAL +	240	LOCKING CAP
208	KEY	219	SOCKET HEAD SCREW	230	GEAR BOX COVER	241	SHIM +
209	SHAFT SEAL (2) +	220	KEY	232	SEAL +	242	SUPPORTING DISK
210	SHAFT SEAL (2) +	221	RETAINING RING +	233	KEY	243	GEAR CASE
211	RETAINING RING +	222	BALL BEARING +	234	DRAIN PLUG (2)	250	LOCKING CAP
212	SHIM +	223	LOCKING CAP	235	SEAL (2) +	254	SPACER

+ RECOMMENDED SPARE PARTS

OUTPUT ASSEMBLY PARTS
Dwg. No. 05-48005

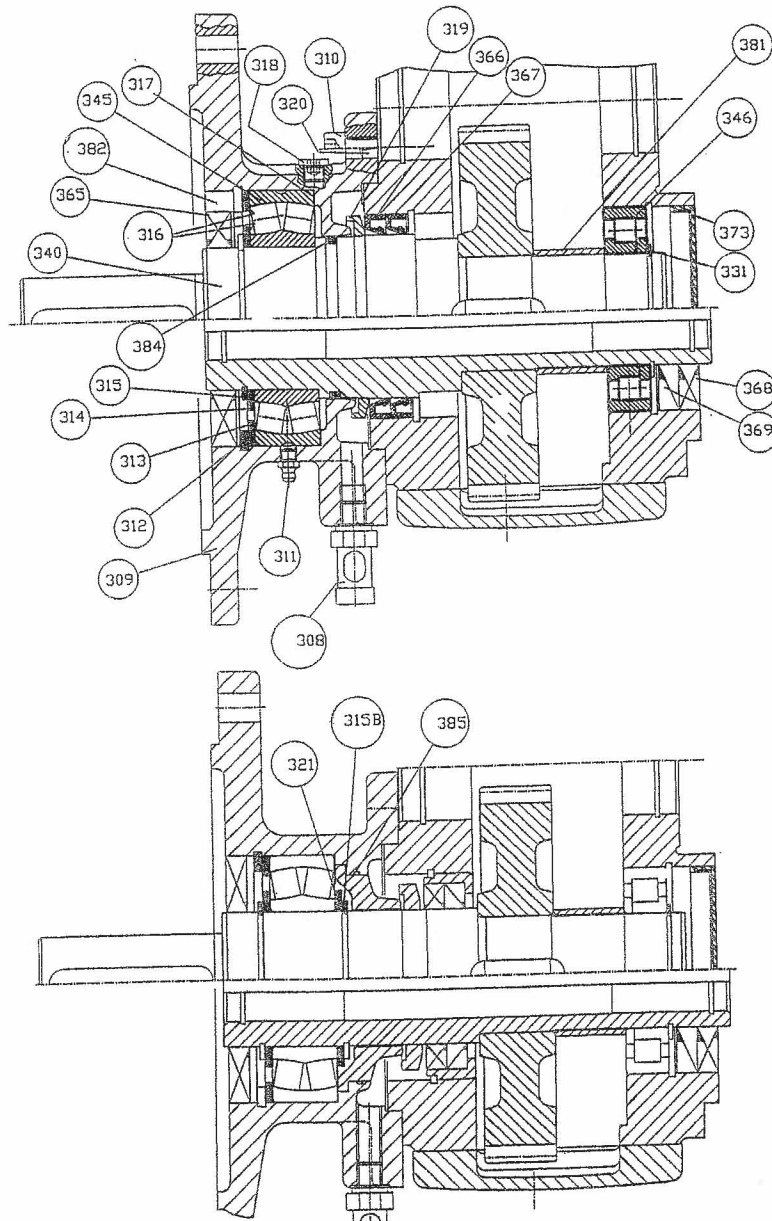

PART NO.	DESCRIPTION	PART NO.	DESCRIPTION	PART NO.	DESCRIPTION	PART NO.	DESCRIPTION
308	OIL INDICATOR	315B	RETAINING RING + *	340	OUTPUT SHAFT/HOLLOW	373	SEAL PLUG +
309	FLANGE	316	SHIM + *	345	SPH ROLLER BEARING +	381	SPACER
310	SOCKET HEAD SCREW	317	SHIM +	346	ROLLER BEARING +	382	SEAL SLEEVE *
311	GREASE FITTING *	318	DRAIN PLUG *	365	OIL SEAL +	384	'O' RING + *
312	RETAINING RING +	319	OIL SLINGER *	366	OIL SEAL +	385	'O' RING + *
313	SPACER	320	GROOVE PIN	367	OIL SEAL +		
314	SPACER	321	SPACER *	368	OIL SEAL +		
315	RETAINING RING +	331	RETAINING RING +	369	OIL SEAL +		

+ RECOMMENDED SPARE PARTS

* MAY BE PART OF OUTPUT SHAFT ON SOME DRIVE SIZES

* PART NOT PRESENT ON ALL DRIVE SIZES

INPUT ASSEMBLY

56C - 180 TC

Dwg. No. 05-47823

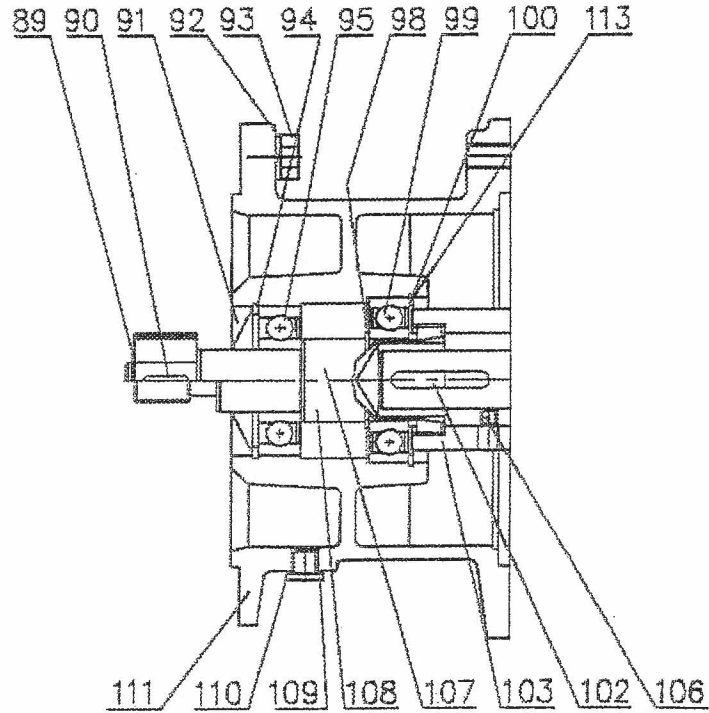

PART NO.	DESCRIPTION	PART NO.	DESCRIPTION
89	RETAINING RING	102	KEY
90	KEY	103	COUPLING
91	SHAFT SEAL	106	SOCKET HEAD SET SCREW
92	WASHER	107	CLUTCH SHAFT
93	HEX HEAD CAP SCREW	108	CLUTCH PINION SHAFT
94	RETAINING RING	109	SEAL
95	CLUTCH SHAFT BEARING	110	OIL PLUG
98	RETAINING RING	111	MOTOR ADAPTER HOUSING
99	CLUTCH SHAFT BEARING	113	SHIM
100	RETAINING RING		

INPUT ASSEMBLY
210TC - 280 TC
Dwg. No. 05-47824

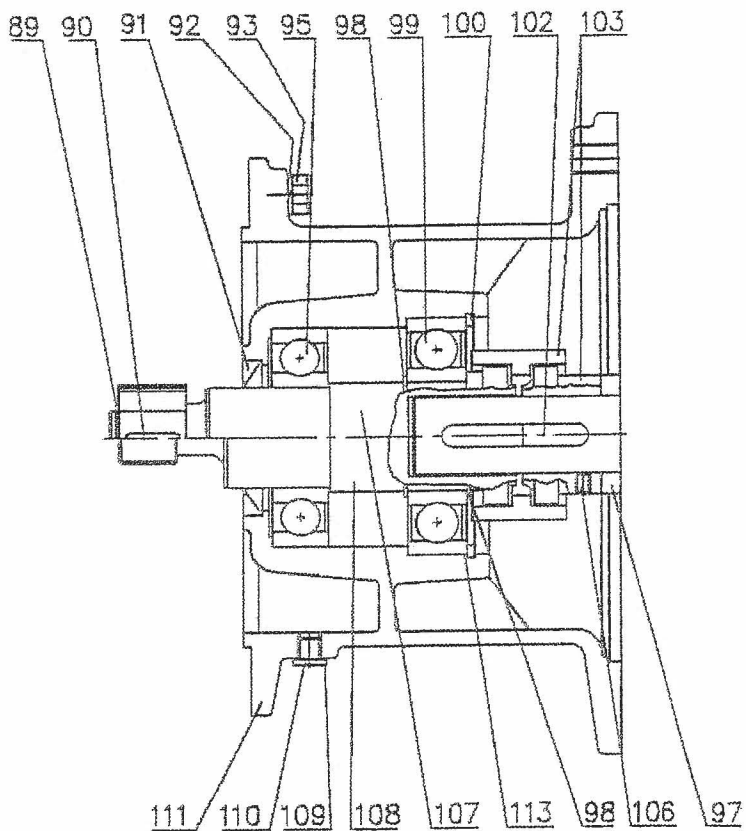

PART NO.	DESCRIPTION	PART NO.	DESCRIPTION
89	RETAINING RING	102	KEY
90	KEY	103	COUPLING
91	SHAFT SEAL	106	SOCKET HEAD SET SCREW
92	WASHER	107	CLUTCH SHAFT
93	HEX HEAD CAP SCREW	108	CLUTCH PINION SHAFT
95	CLUTCH SHAFT BEARING	109	SEAL
97	SPACER	110	OIL PLUG
98	RETAINING RING	111	MOTOR ADAPTER HOUSING
99	CLUTCH SHAFT BEARING	113	SHIM
100	RETAINING RING		

INPUT ASSEMBLY
320TC - 360 TC
 Dwg. No. 05-47755

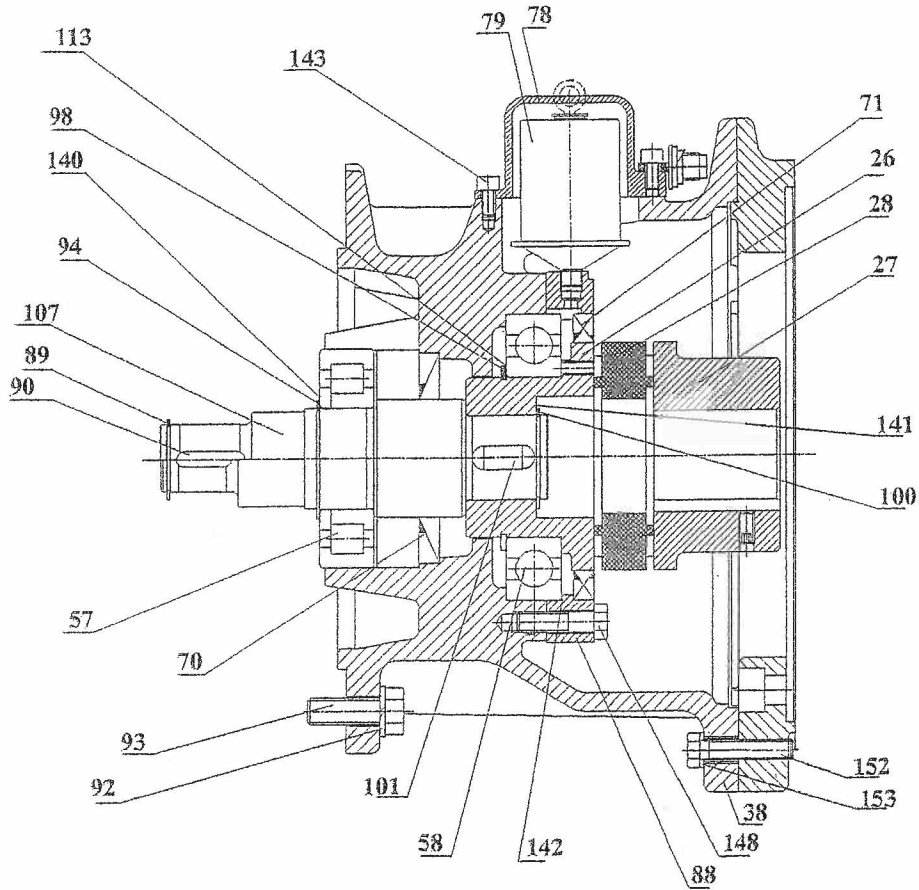

PART NO.	DESCRIPTION	PART NO.	DESCRIPTION	PART NO.	DESCRIPTION
26	COUPLING	88	BEARING COVER	113	SHIM+
27	COUPLING	89	RETAINING RING+	140	SHIM+
28	SPIDER+	90	KEY	141	SHIM+
38	ADAPTER HOUSING	92	LOCK WASHER	142	SHIM+
57	ROLLER BEARING+	93	HEX HEAD CAP SCREW	143	SOCKET HEAD CAP SCREW
58	BALL BEARING+	94	RETAINING RING+	148	HEX HEAD CAP SCREW
70	OIL SEAL+	98	RETAINING RING+	152	HEX HEAD CAP SCREW
71	OIL SEAL+	100	RETAINING RING+	153	LOCK WASHER
78	CARTRIDGE COVER	101	KEY		
79	LUBRICATOR CANISTER+	107	INPUT SHAFT		

+ RECOMMENDED SPARE PARTS